

May 15, 2026

Notice Regarding the Formulation of the Medium-term management Policies

Company name: Unipres Corporation
Representative: Nobuya Uranishi, President and Representative Director
Securities code: 5949 (Tokyo Stock Exchange, Prime)
Contact: Masaki Watanabe, Senior Vice President
Tel. +81-45-278-3500
Website: <https://www.unipres.co.jp/>

We are pleased to announce that we have established medium-term management policies for the period FY2026-FY2028, with the aim of realizing management that is conscious of the cost of capital and stock price, as shown in the attached document.

FY2026-2028 Medium-term Management Policies:

Action to Implement Management that is Conscious of Cost of Capital and Stock Price

The external environment surrounding our company continues to become increasingly uncertain.

In addition to rising geopolitical risks, the future is difficult to predict, as each of our clients is restructuring their strategies in response to the global slowdown in the transition to EVs.

Given these circumstances, and because there are significant uncertainties regarding plans for FY2028 and beyond, quantitative targets will cover FY2026 and FY2027.

In FY2026 and FY2027, we will accelerate strategic technology development and sales expansion activities for new products and fields, based on the completion of structural reforms.

- 1. Analysis of the current situation**
 - 2. Policies and targets**
 - 3. Measures to be undertaken**
-

- 1. Analysis of the current situation**
 2. Policies and targets
 3. Measures to be undertaken
-

Changes of ROE, ROIC, and PBR

- Improved core earning power driving ROIC recovery
- ROE turned negative due to impairment loss related to restructuring of production system

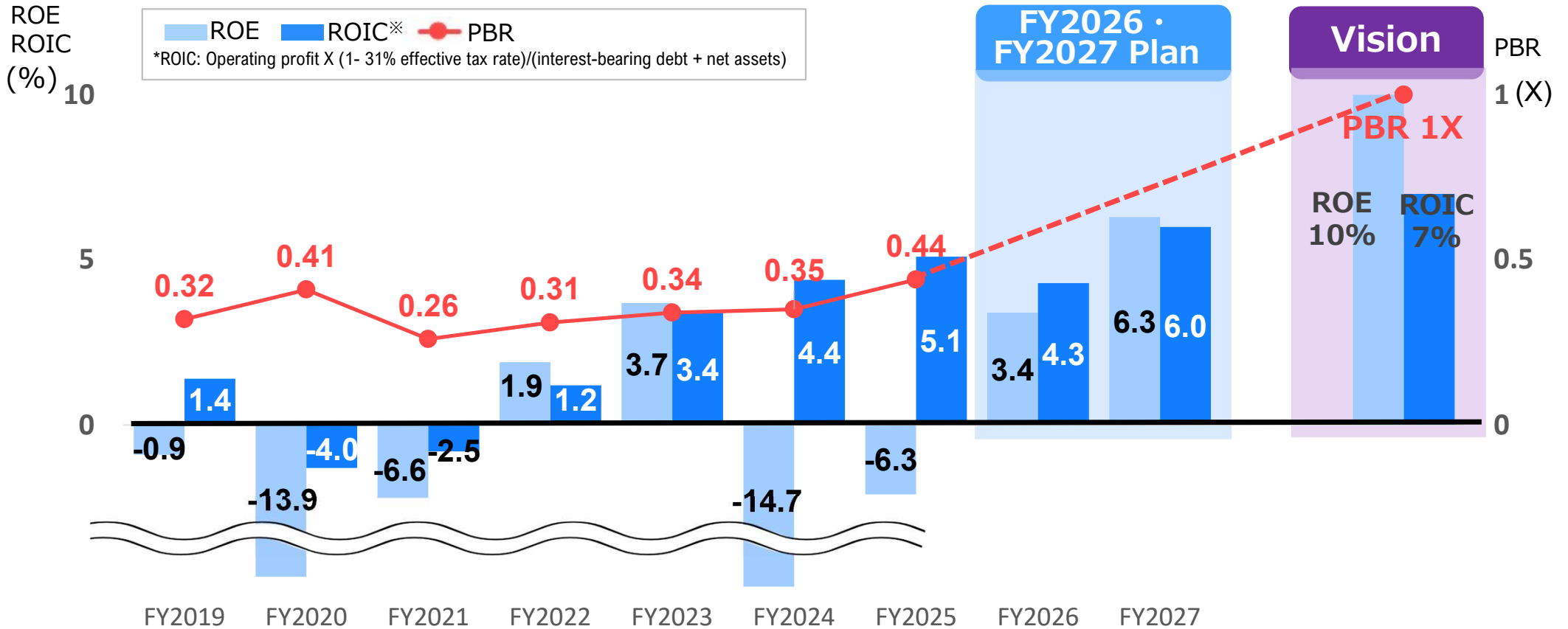

Comparison of PBR with Peers

PBR improving steadily relative to peers

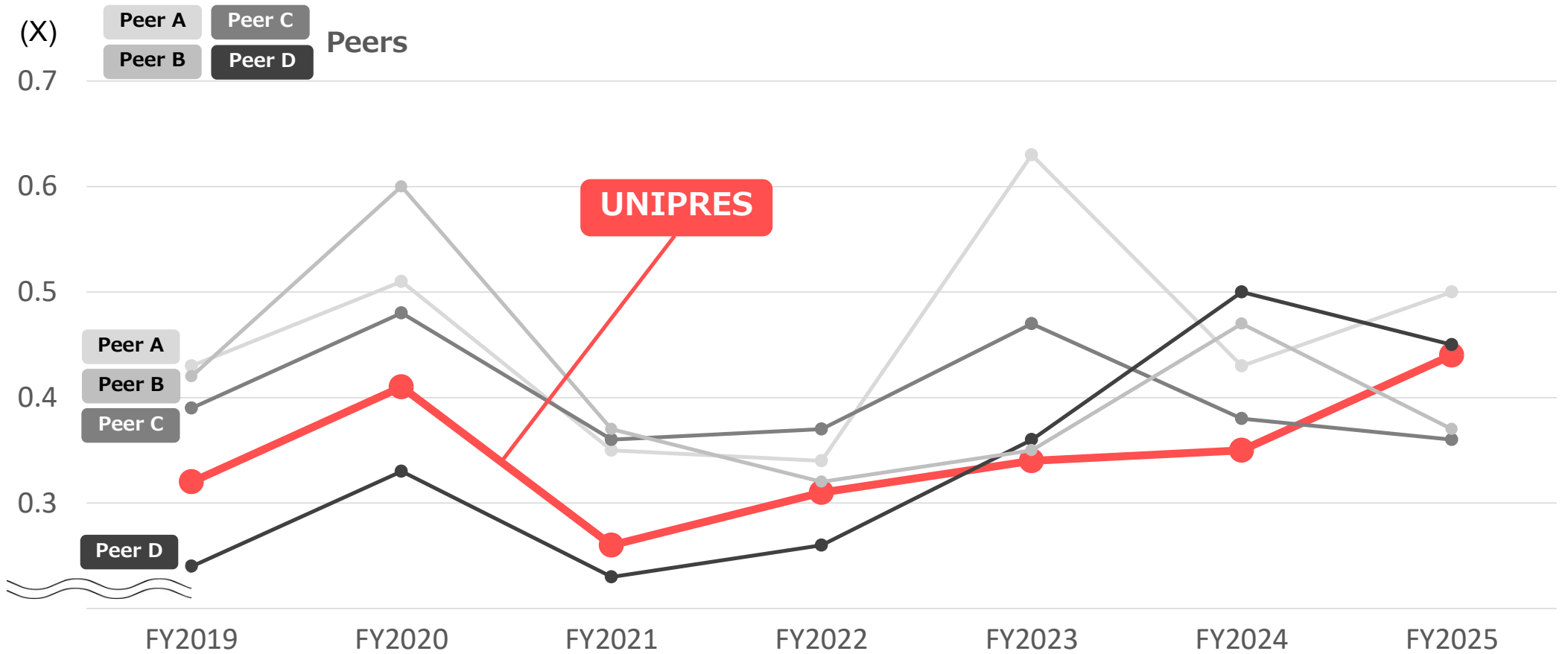

The Relationship Between Shareholders' Equity Cost and ROE

- Steady recurring profit growth despite significant decline in unit production since FY2019
- Continuing to boost profitability and manage equity toward ROE targets

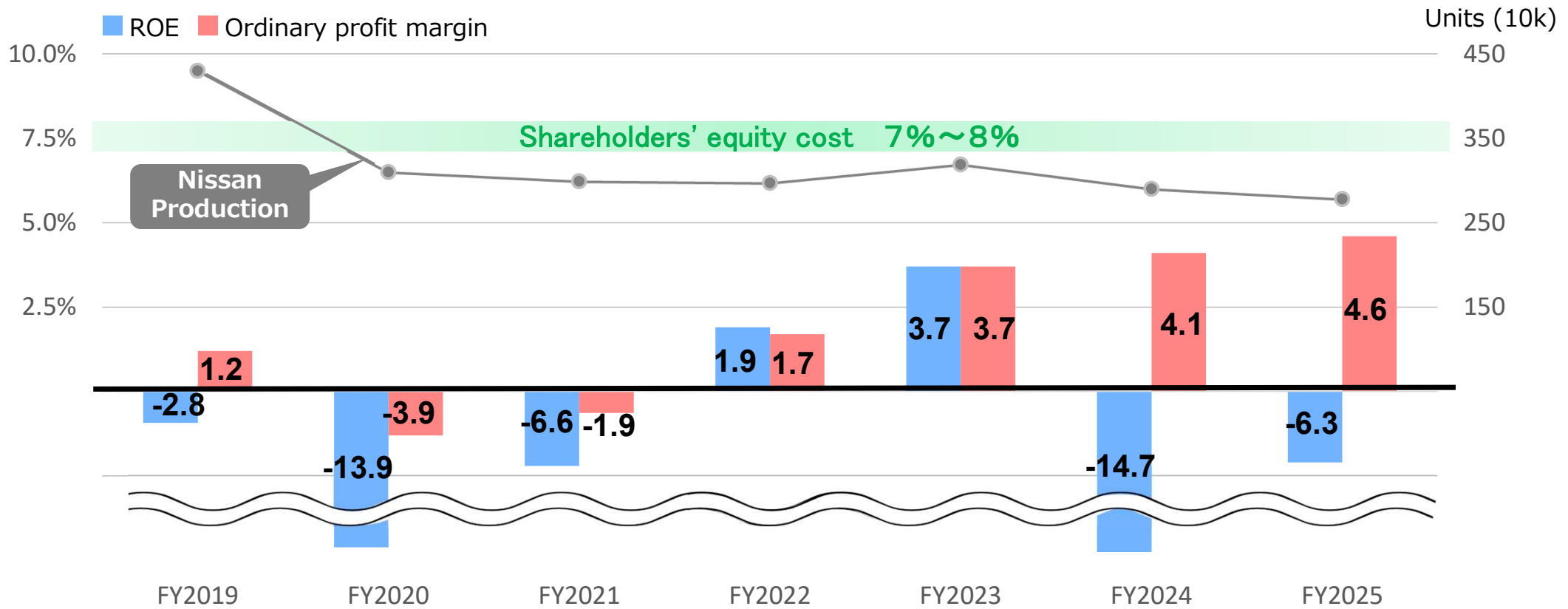

1. Analysis of the current situation
 - 2. Policies and targets**
 3. Measures to be undertaken
-

Current Environment and Issues to be Addressed

Current environment

Changes in auto manufacturer trends

- Rapid global expansion of Chinese automakers
- Automakers revising product strategies amid EV slowdown

Uncertain economic trend

- Escalating geopolitical risks
- Inflation concerns driven by surging energy prices

FY2026

FY2027 onwards

Structural reform

Build optimal production system

Smartification

Improve cost competitiveness

Growth strategy

Enhance/accelerate strategic technology development

Unwavering Focus on Corporate/ Shareholder Value Maximization

In addition to business and financial aspects,
strengthen initiatives targeting different stakeholders

Improvement of PBR

Enhancement of ROE

Business strategies

- Build optimal production system
- Improve cost competitiveness through smartification
- Enhance/accelerate strategic technology development

Financial strategies

- Resilient revenue structure that can withstand changes in production volume
- Optimal equity capital for the business structure

Improvement of PER

Enhancement of shareholder returns

- Dividend policy with DOE as an indicator
- Flexible acquisition of treasury stock

Growth expectations

- Achieve Sustainability Management
- Enhance communication with investors

FY2026-2028 Medium-term Management Policies

Quantitative Target

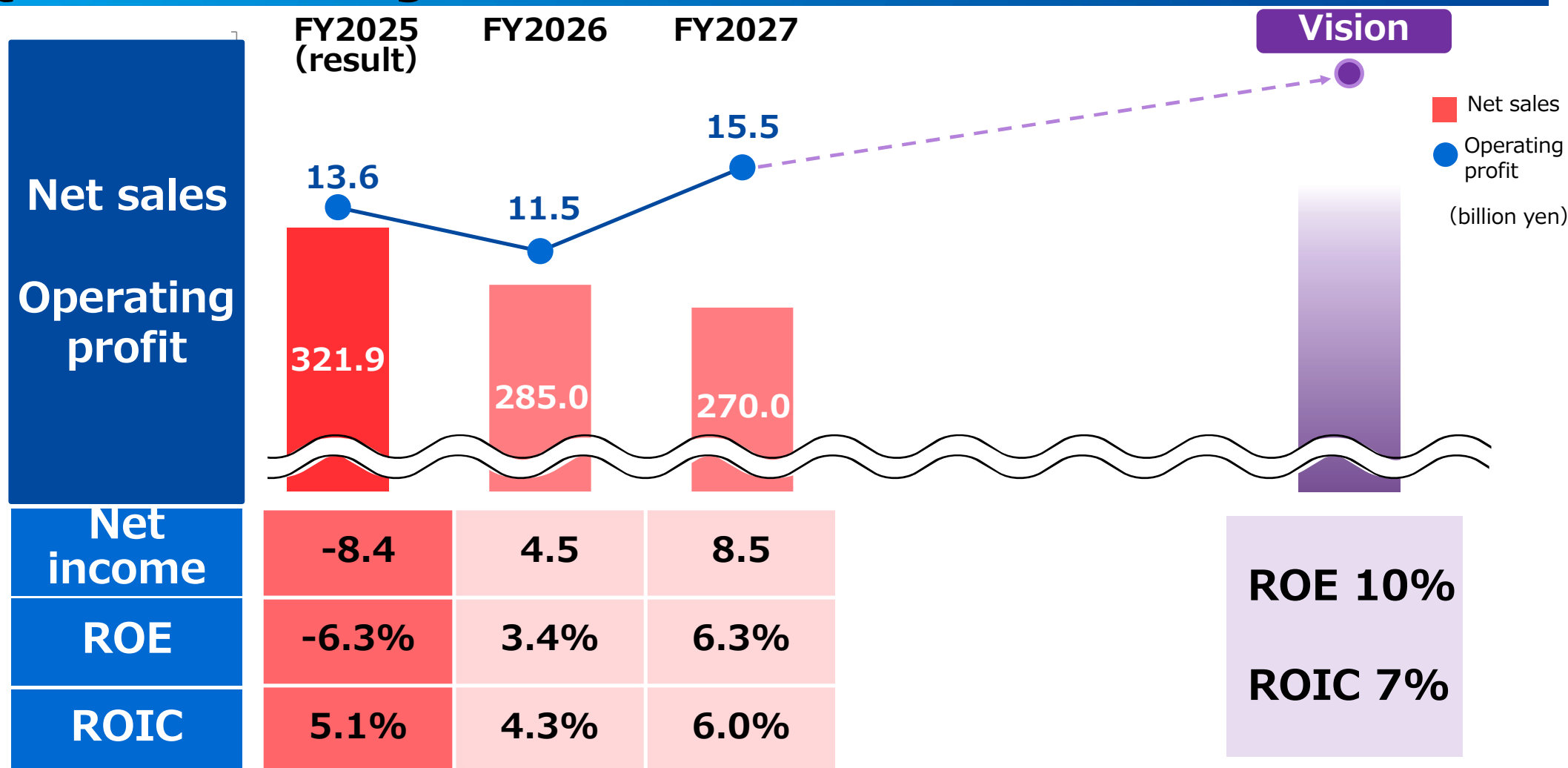

1. Analysis of the current situation
 2. Policies and targets
 - 3. Measures to be undertaken**
-

Business Strategies

Business Strategies

Shareholder return
enhancement

Financial strategies

Growth expectations



13

Structural reform

**Build optimal
production system**

**Fundamental review
of the production
system**

Smartification

**Improve cost
competitiveness**

**Strengthen initiatives
for achieving smart
plants and smart
development**

Growth strategy

**Enhance /accelerate
strategic technology
development**

**Accelerate technology
development for new
products and areas, in
addition to increasing
added value of existing
products**

【Structural reform】 Build Optimal Production System

Business Strategies	Shareholder return enhancement
Financial strategies	Growth expectations

Fundamental restructuring of production systems

●: Retained sites ⦿: Sites to be reduced or closed

Black: Completed Red: Planned

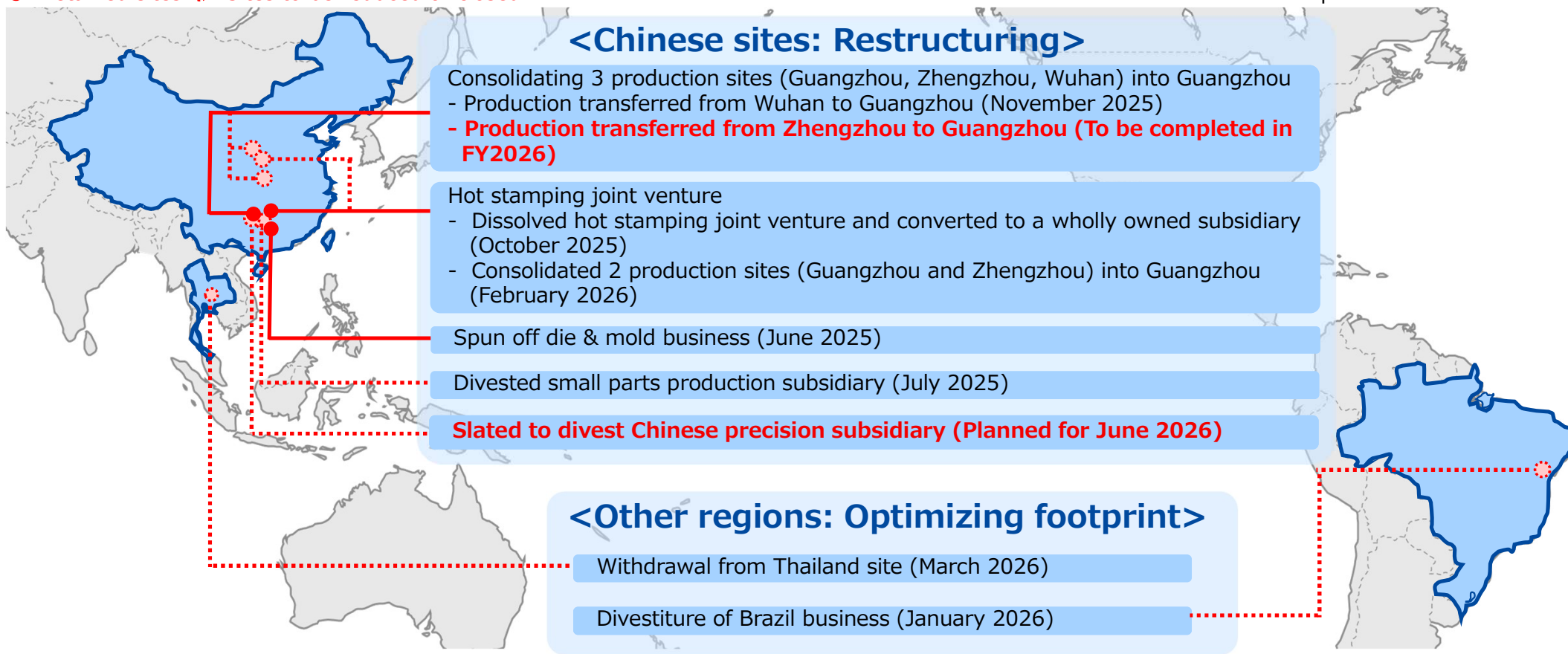

【Structural reform】 Build Optimal Production System

Business Strategies	Shareholder return enhancement
Financial strategies	Growth expectations

From FY2026: Complete China overhaul of production system and drive major Japan restructuring to ensure profitability resilient to volume fluctuations

<Restructuring of Japan sites>

Consolidating car body production into Oyama and Moka Plants

- Production transfer and closure of Tochigi in-site (Planned for FY2026)
- Production transfer and closure of Sagami car body Plant (Planned for FY2027)
- Production transfer and closure of Oppama in-site (Planned for FY2028)

Consolidating precision production into Fuji Plant and Unipres Precision

- Transfer mass production of parts from Fujinomiya Plant and convert to service parts plant (Planned for FY2028)
- Production transfer and closure of Fujinomiya in-site (Planned for FY2028)

- Car body plant
- Plastic plant
- Precision plant
- Tool & die plant
- Sites to be reduced or closed

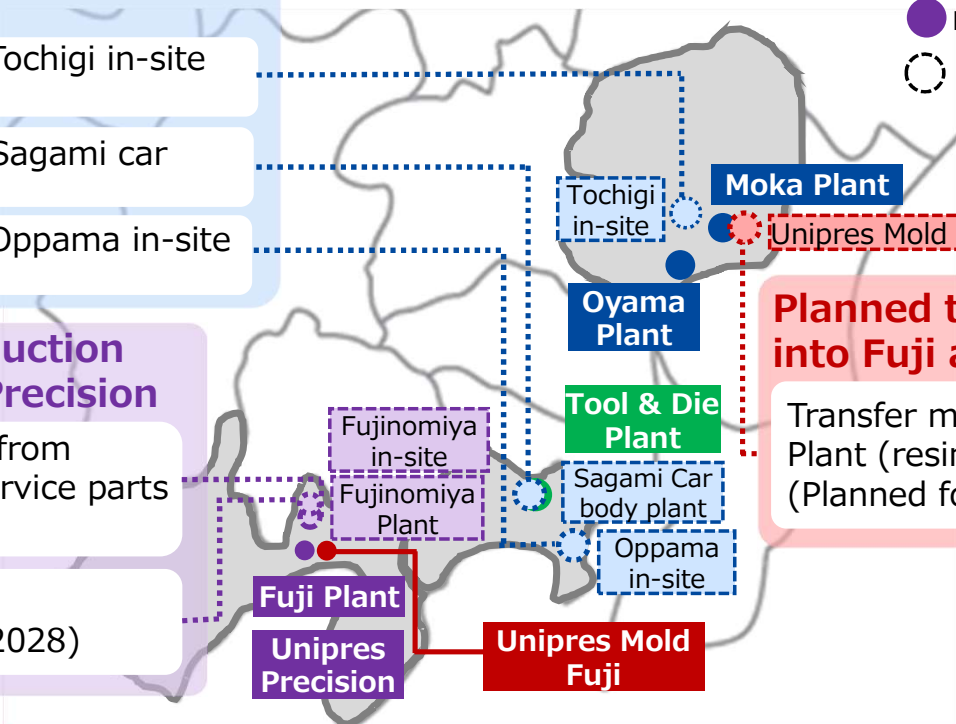

Planned to consolidate resin production into Fuji and Hiroshima Plants

Transfer mass production of parts from Moka Plant (resin) and convert to service parts plant (Planned for FY2027)

【Structural reform】 Build Optimal Production System

Business Strategies	Shareholder return enhancement
Financial strategies	Growth expectations



Consolidating production sites to lower break-even point

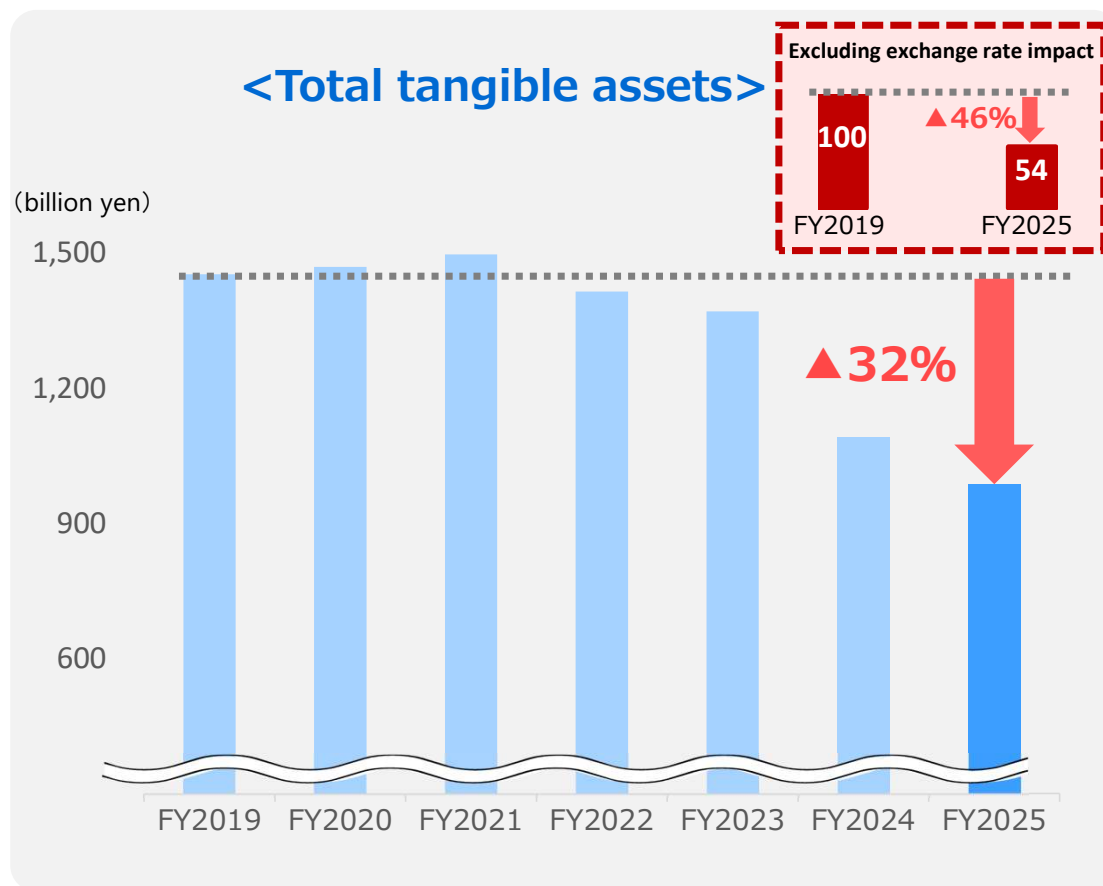
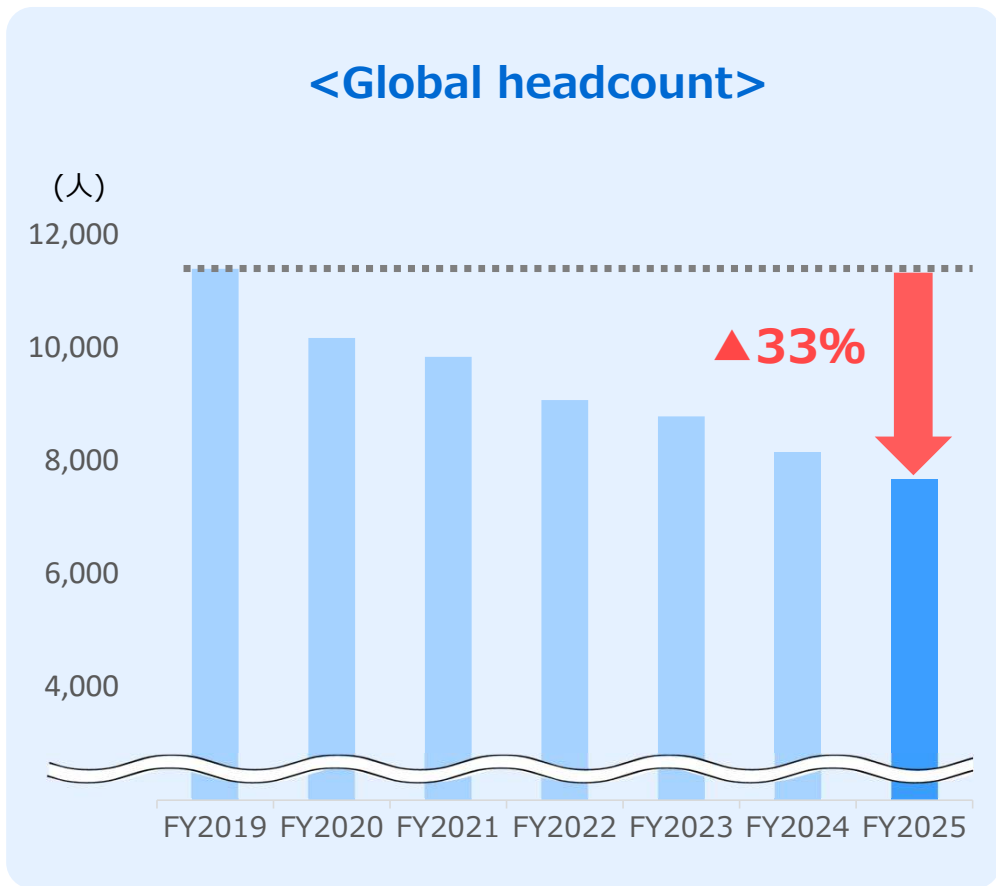

【Smartification】 Improve Cost Competitiveness (smart plants)

Business Strategies	Shareholder return enhancement
Financial strategies	Growth expectations



Capturing valuable field insights to enable smart operations using IT technologies

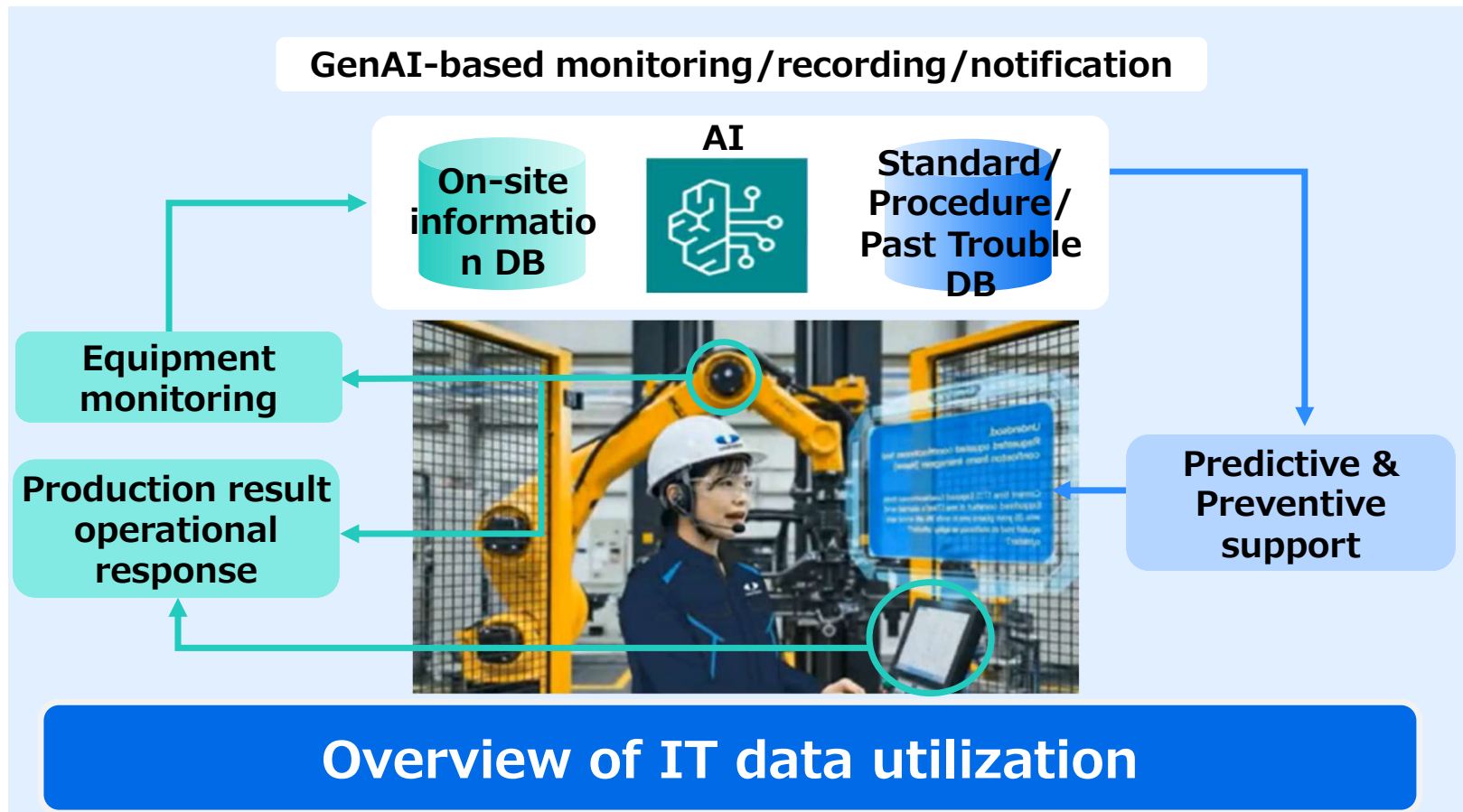

【Growth strategy】 Enhance/accelerate strategic technology development

Further strengthening foundation core technologies to enhance the value of existing products and drive strategic technology development for new products and fields in future

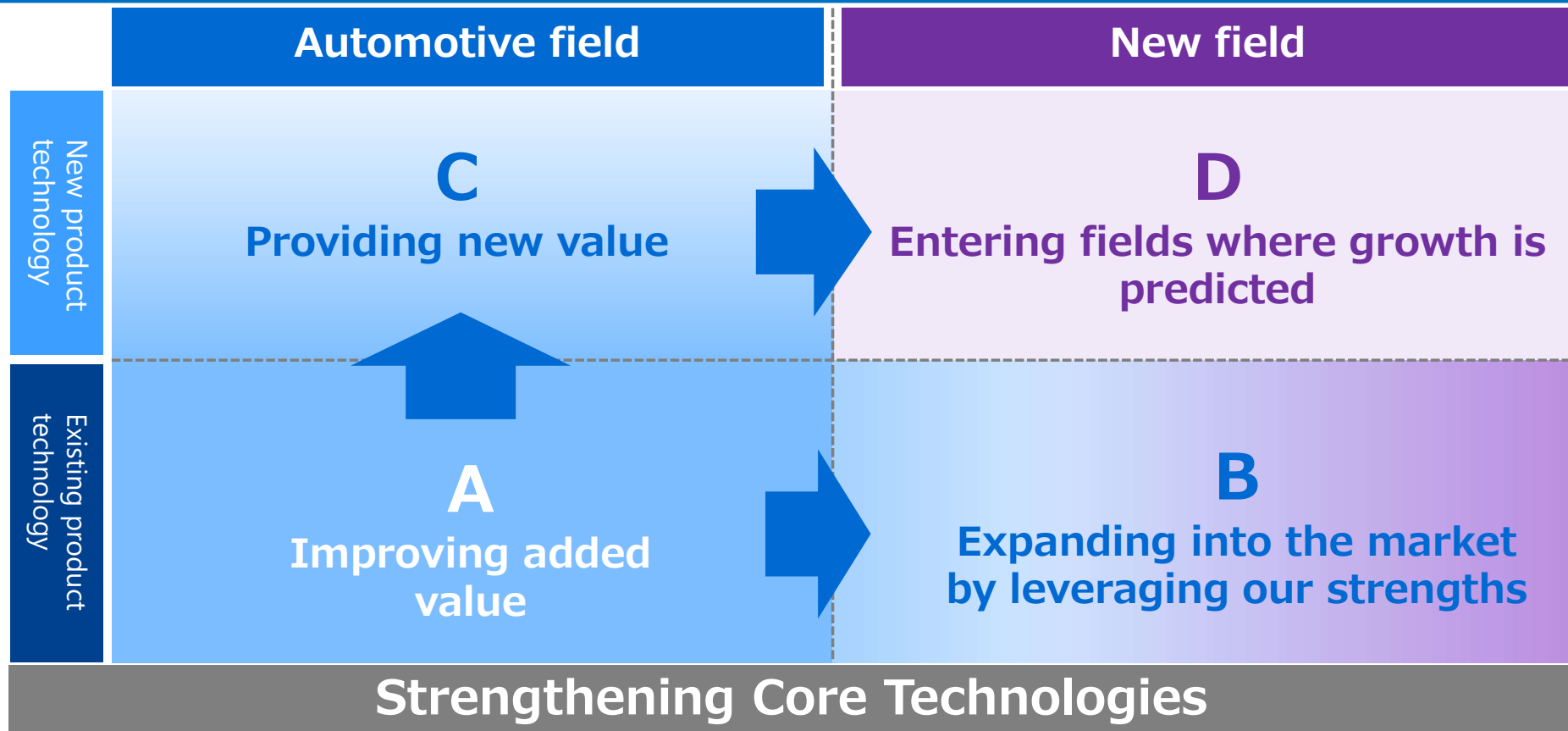

【Growth strategy】 Enhance/accelerate strategic technology development

- Automotive field: Expanding inquiries, mainly for cost-reduced and weight-reduced HEV components
- New field: Enhancing market research and product development to boost number of in-house developments

Growth trend in number of inquiries

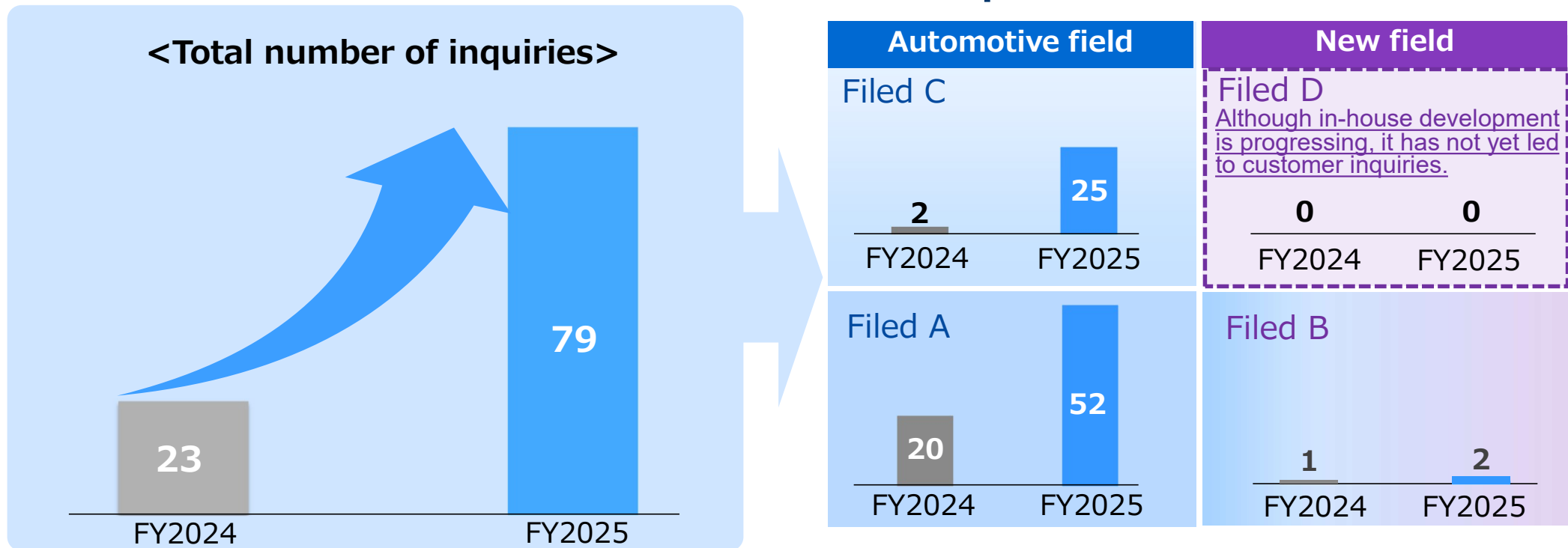

【Growth strategy】 Enhance/accelerate strategic technology development

Business Strategies	Shareholder return enhancement
Financial strategies	Growth expectations

<Inquiry acquisition status> Automotive field : Filed A

Car body parts

- Integration of existing parts through hot-stamping



- Tailor-tempered hot-stamped parts



- Parts utilizing cold-rolled 1.5GPa material



- Small-radius bathtub structure (Battery case, etc.)



- Aluminum stamped parts



- Parts utilizing hot-stamped 2.0GPa material



Precision parts

- Toothed parts

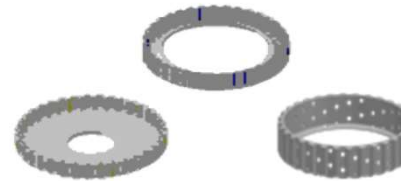

- Carrier parts

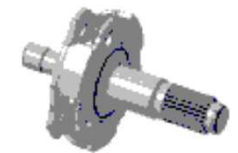

- Plate parts



- Damper



- Piston parts



- Inverter cover

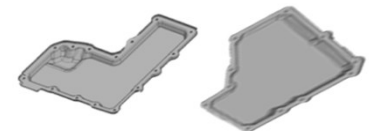

【Growth strategy】 Enhance/accelerate strategic technology development

Business Strategies	Shareholder return enhancement
Financial strategies	Growth expectations

<Inquiry acquisition status> Automotive field : Filed C

Car body parts

- Large-scale integrated hot-stamped components
(Rear frame, door ring, front floor)

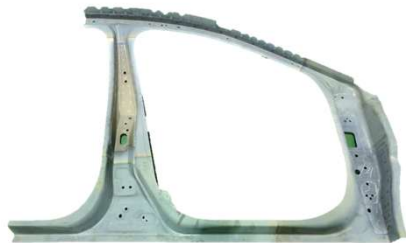

- Multi-material components



Precision parts

- Long busbar



- Drive shaft



- Seat adjuster plate



Plastic parts

- Large-scale full-flat cover (3-layer foamed sheet)



- Sound-absorbing undercover (Acoustic sheet)





- Sound-absorbing fender protector (Acoustic sheet)



【Growth strategy】 Enhance/accelerate strategic technology development

Business Strategies	Shareholder return enhancement
Financial strategies	Growth expectations

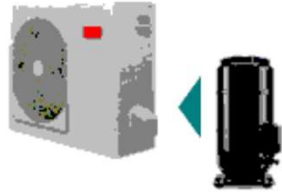
<Inquiry acquisition status> **New field : Filed B**

Air conditioner field	Seat field	Versatile mobility field
 <p><u>Compressor parts</u></p>	 <p><u>Seat frame parts</u></p>	 <p><u>Gearing components</u> <u>Clutch parts</u></p>

【Growth strategy】

Enhance/accelerate strategic technology development
(Future goals through core technology development)

Business Strategies	Shareholder return enhancement
Financial strategies	Growth expectations



Accelerate core technology development to improve added value and expand market reach through launching new products, and increase revenue

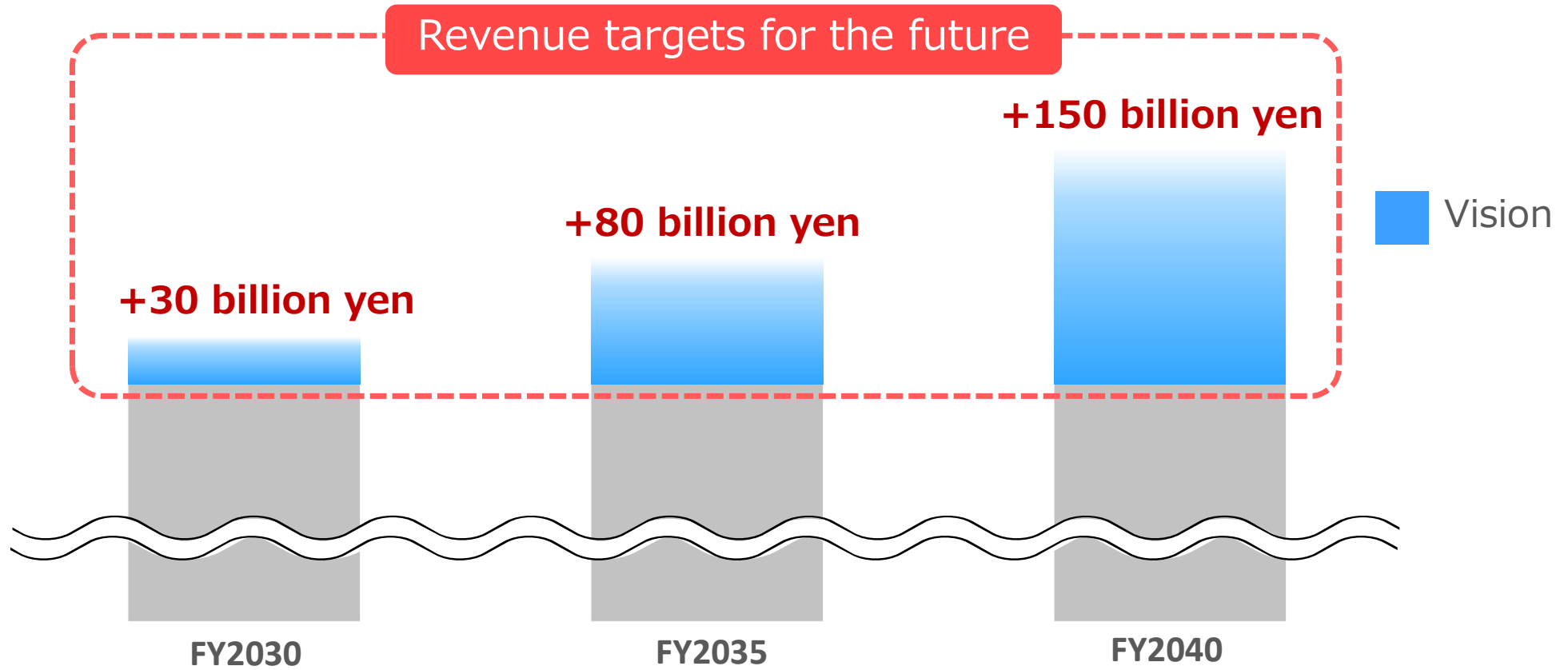

【Growth strategy】

Enhance/accelerate strategic technology development
(Future goals through core technology development)

Business Strategies

Shareholder return
enhancement

Financial strategies

Growth expectations



Models Starting Mass Production in FY2025

Nissan



LEAF (Japan・UK)



ROOX (Japan)



SENTRA (Mexico)



VERSA (Mexico)



Rogue PHEV (Japan)



SYLPHY (China)



N6 (China)



NX8 (China)

Renault



Duster (India)



Alpine A390
(France)



Kangoo E-TECH
(France)

Honda



N-One e: (Japan)

MITSUBISHI



ECLIPSE CROSS
(France)



DELICA mini/
eK SPACE (Japan)

Mazda



CX-5 (Japan)

SUZUKI



FRONX (Indonesia)

Revenue Structure Enhancement and Appropriate Level of Equity Capital

Business Strategies

Shareholder return enhancement

Financial strategies

Growth expectations



Resilient revenue structure that can withstand changes in production volume

(billion yen)

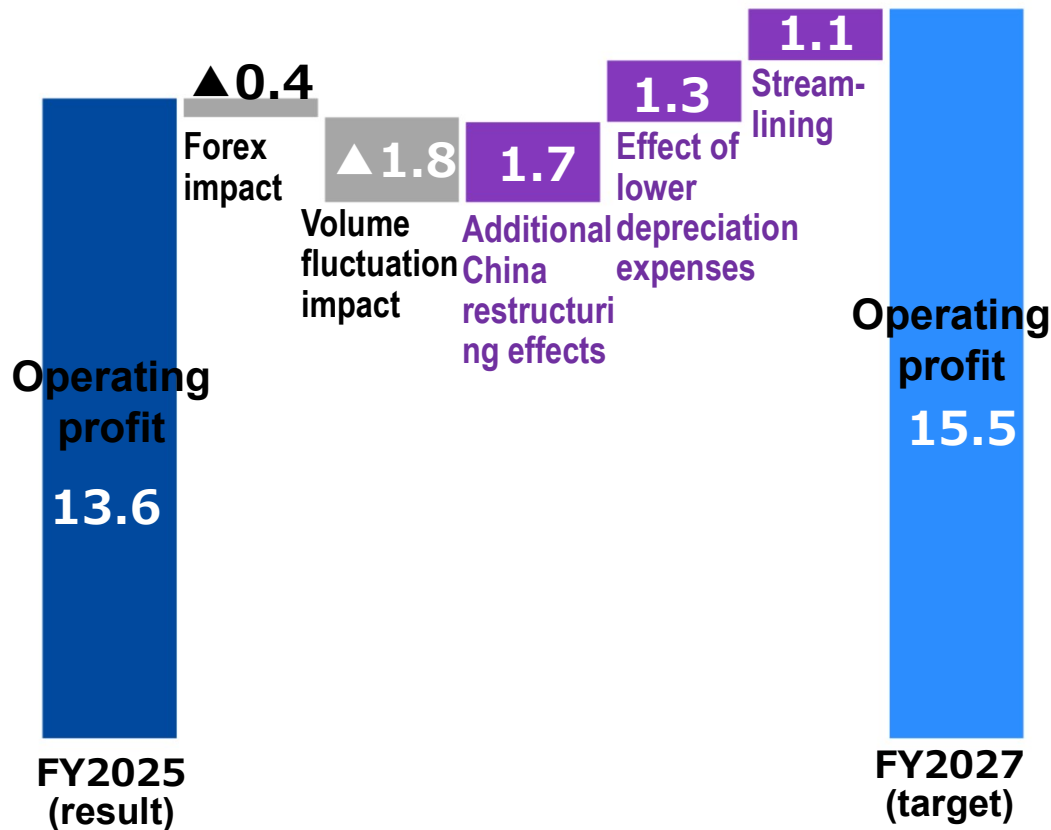

Optimal equity capital for the business structure

(billion yen)

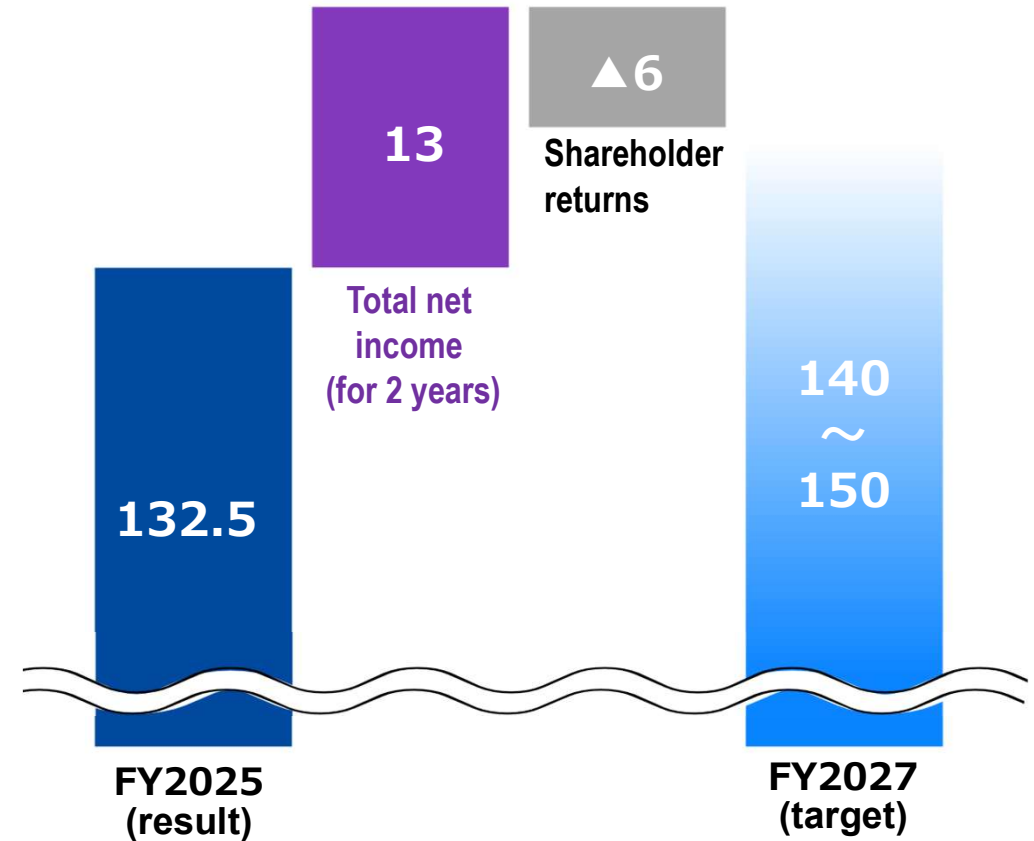

Cash Allocation

- Cumulative total for 2 years from FY2026 to FY2027

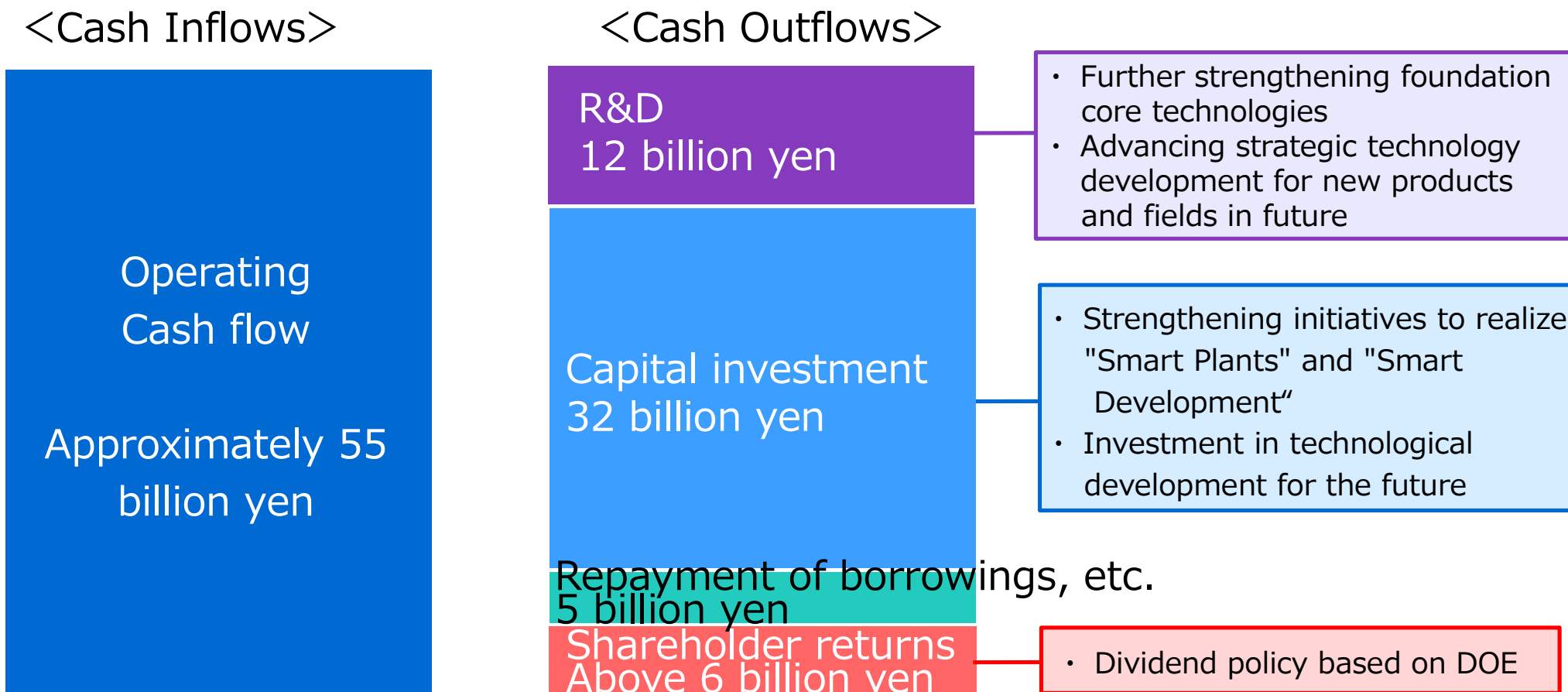

Enhancement of shareholder returns

- Maintain DOE as a key dividend metric, targeting 3% in the medium term
- Maintain appropriate capital levels with a focus on increasing dividends, while considering acquisition of treasury stock as an additional option

(yen/share) ■ Year-end dividend
 ■ End of 2nd quarter dividend

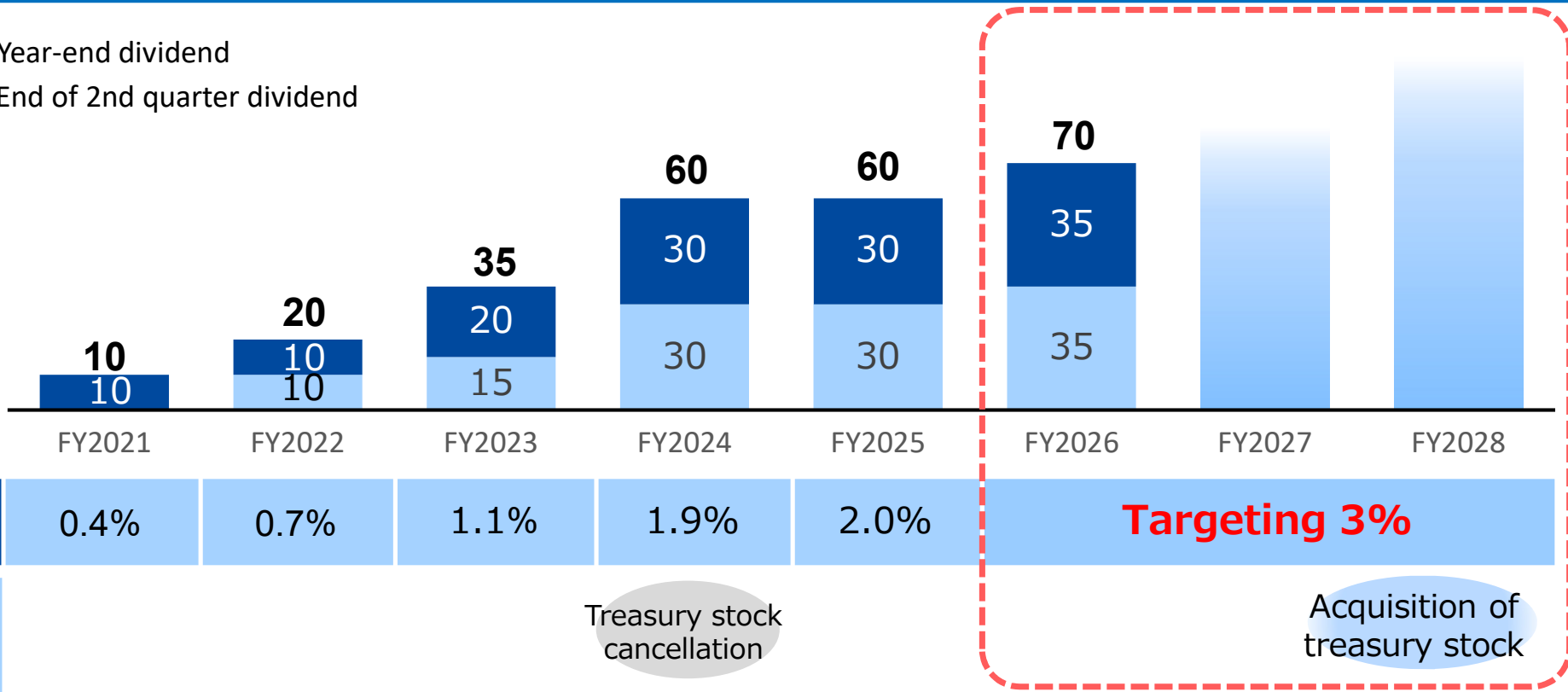

Achieve Sustainability Management

Business Strategies

Shareholder return
enhancement

Financial strategies

Growth expectations



28

Aiming to create social values in addition to economic values, we are committed to well-being, ESG initiatives, and carbon neutrality

Well-being

• Strengthen human capital

- ✓ Implementation of career enhancement measures
- ✓ Further increase in the ratio of women in management positions
- ✓ Improvement of psychological safety (e.g., training for all managers)
- ✓ Improvement of health literacy

ESG initiatives

• Efficient use of resources

- ✓ Expand use of recycled materials
- ✓ Improve recycling ratio for industrial waste

• Promote social contribution activities

- ✓ Promote activities focusing on environmental preservation, fostering next-generation and community activities

• Enhance compliance

Carbon neutrality

• Promote carbon neutrality

(FY2050: Net zero GHG emissions from business activities)

- ✓ Promote green product development
- ✓ Use renewable energy
- ✓ Promote energy saving activities

Achieve Sustainability Management (Well-being)

Business Strategies	Shareholder return enhancement
Financial strategies	Growth expectations

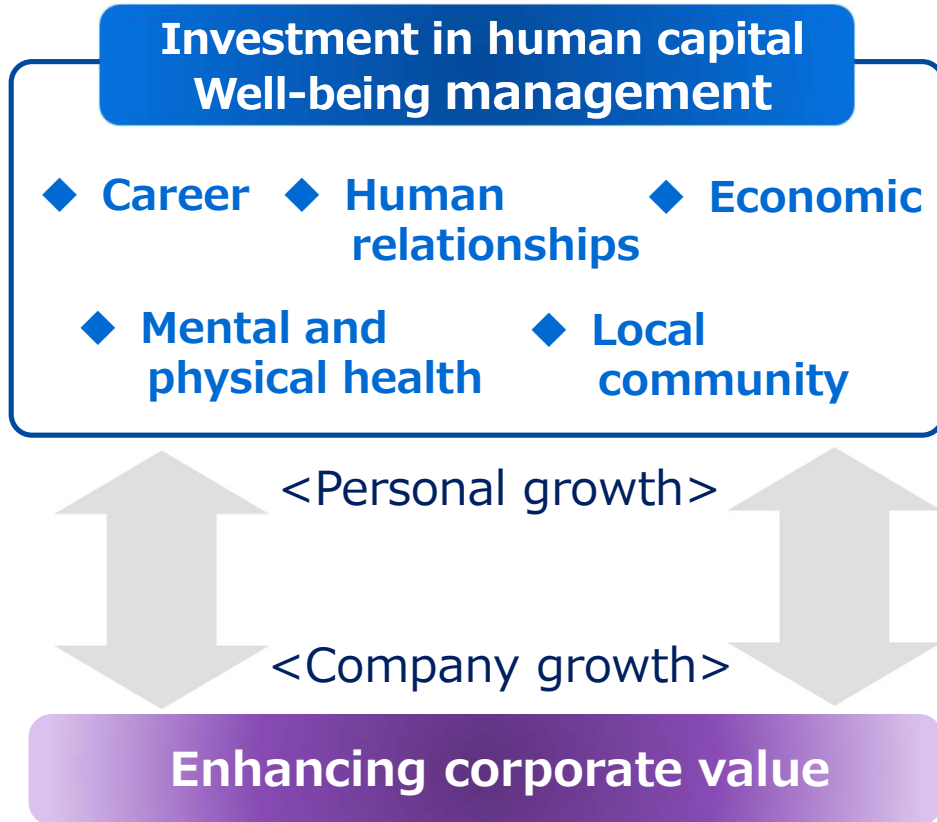

Major initiatives in FY2025

- ✓ Promoting male paternity leave
- ✓ Promoting a family-friendly work environment
- ✓ Strengthening initiatives to promote employee well-being (Launching a smoking cessation supporter program, expanding women's health webinars and health-related leave systems)
- ✓ Creating dialogue opportunities between female outside directors and female staff
- ✓ Continuous wage level increases

External evaluations



(Certified in 2025)



(Certified for 6 consecutive years since 2021)

Achieve Sustainability Management (ESG initiatives)

Business Strategies

Shareholder return
enhancement

Financial strategies

Growth expectations



E

(Environment)

- The industrial waste recycling rate has been significantly increased by recycling sludge generated during the lubrication process prior to press processing as a cement raw material and by promoting the recycling of packaging materials and powder coating materials.
- Third-party certification of GHG emissions was obtained at all sites, including overseas subsidiaries in scope.

G

(Governance)

- The internal whistleblowing system (external contact) was expanded to include suppliers, and a framework was established for the entire supply chain to detect violations of the revised Subcontract Act, Antimonopoly Act, and other laws and regulations, as well as human rights risks such as harassment, at an early stage and to provide remedial measures.
- The information security system was strengthened by managing it in accordance with the Automotive Industry Cyber Security Guidelines, conducting audits, and reorganizing the business continuity plan in the event of a cyber incident.

S

(Social)

- The company engages in a variety of social contribution activities at its sites in Japan, including forest and biological conservation. In FY2025, 23 initiatives were implemented, with 500 employees participating in total.



Forest restoration partner initiative

- Overseas, activities are centered around three priority areas: environmental preservation, next-generation development, and community activities.



[Environmental preservation]
Tree-planting initiative



[Next-generation development]
Children's recreation



[Community activities]
Food bank

Achieve Sustainability Management (Carbon neutrality)

Business Strategies

Shareholder return
enhancement

Financial strategies

Growth expectations



Achieved 50% reduction in GHG emissions due to steady implementation of initiatives and impact of reduced production

[GHG (greenhouse gas) reduction targets]

- FY2030: 50% reduction of GHG emissions emitted from business activities (compared to FY2018)
- FY2050: Net zero GHG emissions emitted from business activities
- FY2050 challenge: Work together with suppliers to achieve net zero GHG emissions

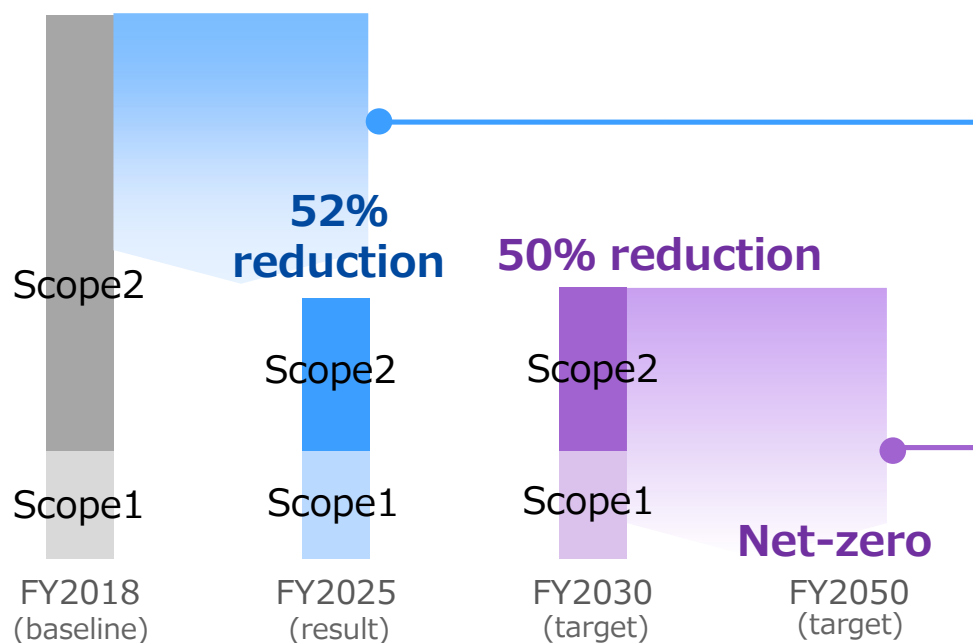

<Initiatives>

- **Promoting the adoption of solar power generation**
Installation completed at all domestic sites and expanded to 6 sites in 4 countries overseas
- **Thorough implementation of energy conservation activities**
Reduce consumption continuously by improving the efficiency of production facilities
- **Enhancing the shift to CO₂-free electricity**
Expanding the use of renewable electricity

<Future initiatives>

- **Accelerating energy conservation and energy transition**
- **Utilization of carbon offsets**
- **Accelerate deployment of renewable energy to overseas sites**

Materiality achievement status

Business Strategies

Shareholder return
enhancement

Financial strategies

Growth expectations



(✓ : 90% or more △ : 50% to 90% × : Less than 50%)

Materiality	Medium- and Long-Term Targets (FY2030)	FY2025 Targets	Degree of Achievement
Climate Change Countermeasures	50% reduction in CO ₂ emissions from business activities in FY2030 (relative to FY2018)	50% reduction in CO ₂ emissions compared to FY2018	✓
Green Product Development	<Car Body Pressed Parts Business> Integration of frame parts (DOOR-RING, RR-FRAME, FR-FLOOR) Development of battery case	Development of body structure integration technology (RR-FRAME, FR-FLOOR, ENCON, etc.) Development of battery case	✓
	<Precision Pressed Parts Business> Development of e-Axle components Applying pressing technology to cast and forged parts	Development of e-Axle components Applying pressing technology to cast and forged parts (hollow shaft, busbar, etc.)	✓
	<Plastic Pressed Parts Business> Use of bio-based and recycled materials	Development of applications for environmentally friendly fillers Expansion of recycled material applications in the market	△
Efficient Use of Resources	Recycling rate of industrial waste: <u>90%</u> or higher [Unipres Corporation/Unipres Kyushu Corporation]	Recycling rate of industrial waste: 80% [Unipres Corporation/Unipres Kyushu Corporation]	✓
Respect for Human Rights	Zero incidents of serious human rights violations	Zero incidents of serious human rights violations	✓
Promoting Diversity	1. Increased ratio of women managers (7%) [Unipres Corporation]	Percentage of women in management positions: 3.5% or higher	△
	2. Increased ratio (60%) of local employees in senior management positions at overseas locations [Overseas]	Promoting initiatives to expand our North American footprint	✓
Supply Chain Management	[Promoting sustainable purchasing] Zero high-risk suppliers in respect of the environment and society	Zero high-risk suppliers in respect of the environment and society	✓
Strengthening Corporate Governance	1. Zero serious legal violations	Zero serious legal violations	✓
	2. Zero serious anti-corruption policy violations	Zero serious anti-corruption policy violations	✓

Awarded the highest "A" rating in CDP's Supplier Engagement Rating

- The "Supplier Engagement Rating" is a metric that evaluates corporate efforts to address climate change issues across the supply chain.

Companies that make a significant contribution to achieving carbon neutrality by engaging with suppliers to address climate change are selected.

<Initiatives>

- Held supplier meetings to engage partners in our sustainability initiatives, including climate action, and to drive efforts throughout the entire supply chain
- In addition to Scopes 1 and 2, third-party assurance was received for a portion of Scope 3, enhancing the reliability and transparency of our GHG emissions data

Evaluations from customers

Business Strategies	Shareholder return enhancement
Financial strategies	Growth expectations

We received a high evaluation from Nissan for our efforts in relation to the quality of our car body parts, as well as related awards

<Nissan Automotive Europe> Regional Quality Award

The highest honor presented by Nissan to business partners who have contributed to overall quality throughout the year



Second from the left Nissan Motor Corporation AMIEO Region Chairperson, Massimiliano Messina
Second from the right Unipres (UK) Managing Director, Mitsunobu Yamanaka

<Dongfeng Nissan> Excellent Supplier Award

An award presented to the supplier that excels in all areas, including quality, price, delivery, development, and service



<Zhengzhou Nissan> Aftersales Award

An award presented to suppliers who deliver high-quality products on time in response to requests for service parts



Improve Dialogue with Investors

Business Strategies

Shareholder return
enhancement

Financial strategies

Growth expectations



In addition to the dialogue with investors, giving them a tour of our actual production sites helped deepen their understanding of our technological capabilities and initiatives

FY2025 Initiatives

- Engaged in active dialogue with shareholders and investors, and provided feedback on the insights gained to the Board of Directors

	Speakers	Number of events
Briefing for financial results	President and Representative Director, executives in charge of finance, engineering, and plants and production.	2
Individual dialogues with institutional investors and analysts	Executive in charge of finance and executive in charge of IR	6 7
Individual dialogue with proxy voting officers, etc.	Executive in charge of IR	8

Improve Dialogue with Investors

Business Strategies

Shareholder return
enhancement

Financial strategies

Growth expectations

 UNIPRES

36

● Hosts Tour of Unipres Kyushu Plant for Institutional Investors and Analysts

- ✓ On the day of the event, 13 institutional investors and analysts attended. Following an overview of Unipres Kyushu, they toured the heading and assembly plant, the hot-stamping line, and the automated equipment.
- ✓ The visitors deepened their understanding of our integrated production system from coiled material to blanking and pressing, and our efforts to improve productivity, such as reducing operational losses through real-time monitoring, as well as our automated conveyance and automated warehousing.





Pressing Toward a Brighter Tomorrow