

# Integrated Body Structure Component: Rear Frame

- Mass-Produced
- Prototyping Available
- Independent development

Body

## Example of Applied Parts

• Application of Integrated Rear Frame Technology

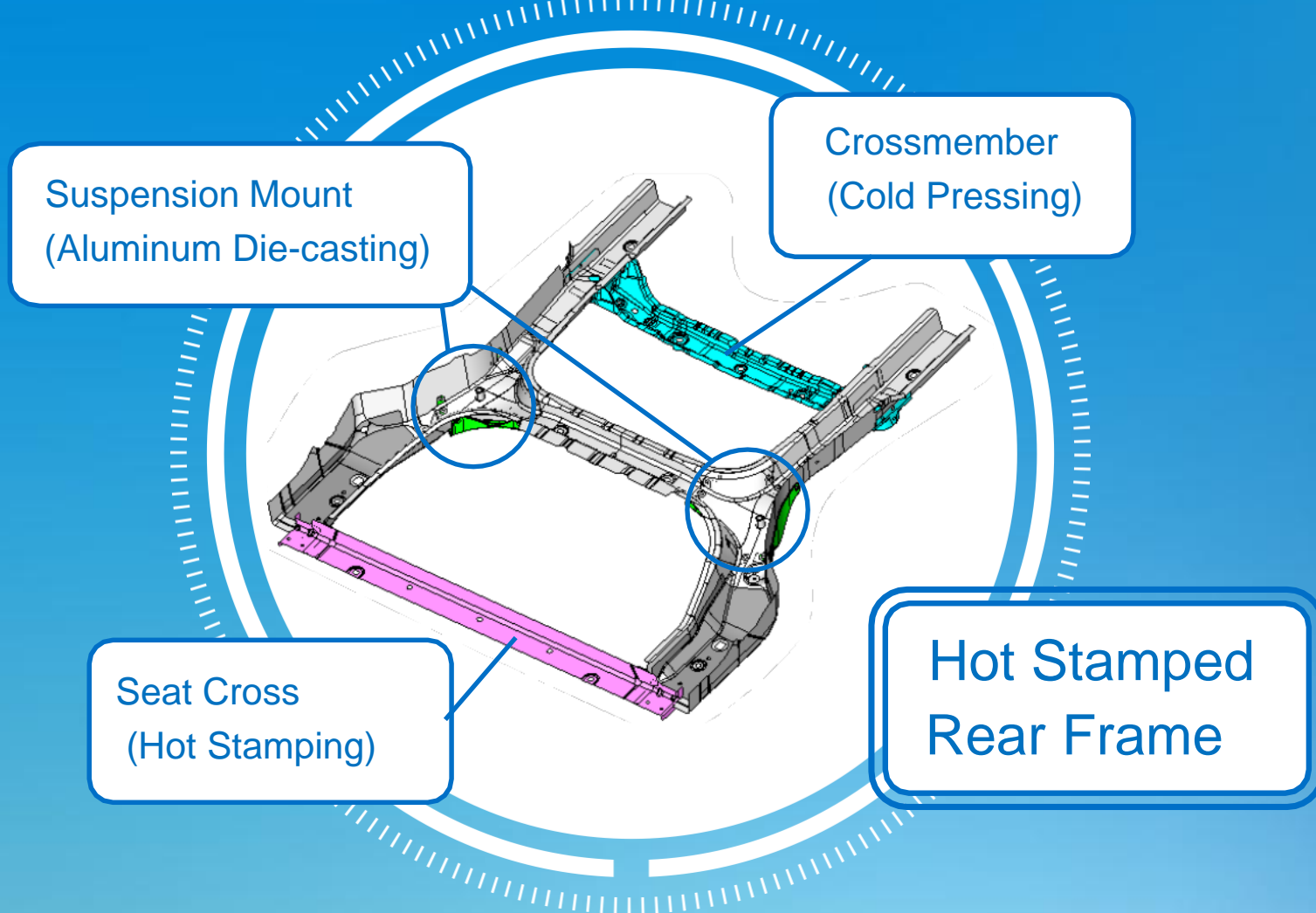

## 「Next-Generation Frame Structure through Integral Forming and Functional Integration」 ~The Next Generation of Vehicle Structures Pioneered by the Integrated Rear Frame~

- By joining the Seat Cross and Crossmember to the developed integrated Rear Frame structure, we have realized the "Final Form" through further functional integration.
- By replacing the Suspension Mount from conventional steel pressed parts with **Aluminum Die-cast parts**, we propose a "Shift in Thinking" for vehicle structures—optimizing stiffness and weight while reducing part counts.

## Implementation Benefits

- ✓ **Significant Reduction in Assembly Man-hours (Line Shortening)**  
By delivering multiple components as a single module, processes on the vehicle assembly line can be reduced.
- ✓ **Improved Handling Stability and Ride Comfort**  
Pinpoint enhancement of rigidity at the suspension input section achieves direct handling and reduced unpleasant vibrations.

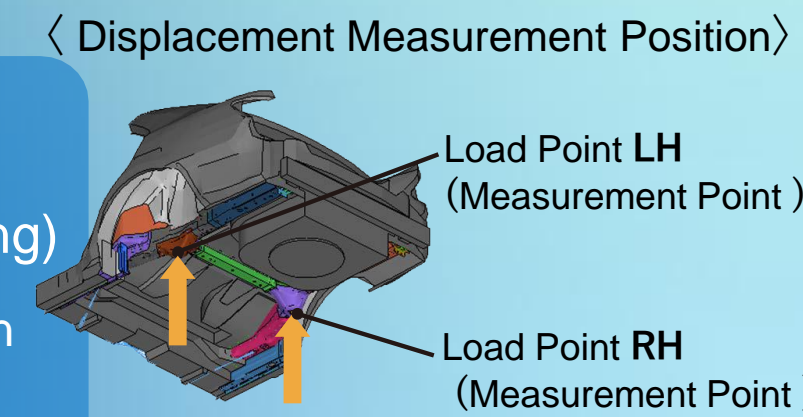

Measurement Results (at equivalent mass)

**38%**  
Reduction

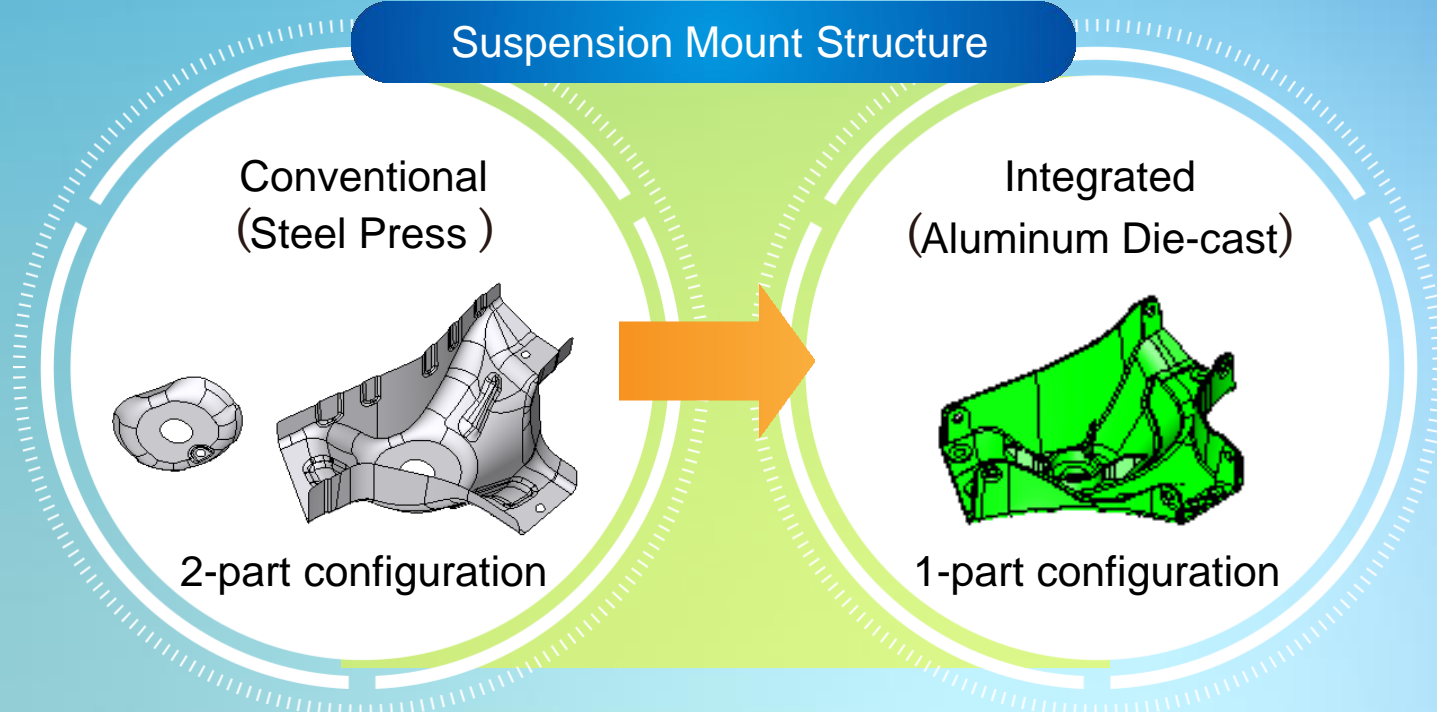

Pressing Toward a Brighter Tomorrow