

Integrated Body Structure Component: Door Ring

- Mass-Produced
- Prototyping Available
- Independent development

Body

Example of Applied Parts

• Application of Integrated Door Ring Technology

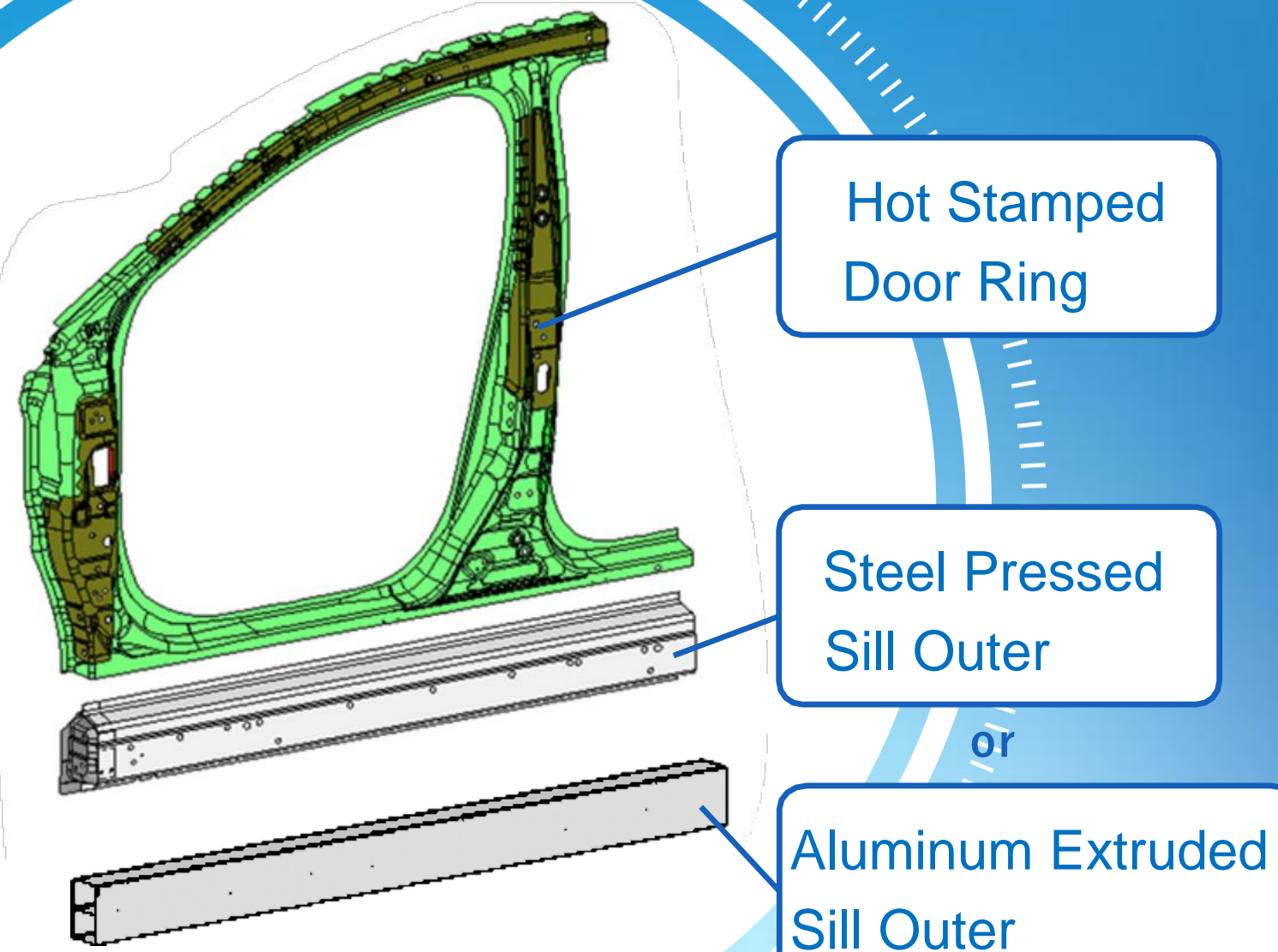

「The Optimal Solution for Next-Generation Door Ring Structures Across BEV, HEV, and ICE Vehicles」

~ Achieving Door Ring Standardization through a Separate Sill Outer Design ~

With the acceleration of electrification, requirements for the lower body structure differ significantly between BEVs and ICE/HEVs due to varying battery protection needs.

Our proposed "**New Door Ring Structure**" achieves standardization of the main door ring body by making the **Sill Outer** a separate component.

Implementation Benefits

✓ Standardization Across Vehicle Types

By standardizing the main structural parts, development costs and capital investment are significantly reduced.

✓ Flexibility to Change

Adaptable to changes in battery capacity or protection requirements simply by adjusting Sill Outer components.



Pressing Toward a Brighter Tomorrow